

BAXI FIRES DIVISION

INSTALLER AND OWNER GUIDE

Model
0581901

Chester

Log Effect Electric Stove



This guide is intended to help you install and care for your Baxi Fires Division electric stove. Please read carefully before installing and using your stove. However, if further information is required, our **Baxi Fires Division Technical Helpline** will be pleased to help.

Telephone **08706 061 065** (National call rates apply in the United Kingdom)
In the Republic of Ireland call **0044 8706 061 065**

Important: Please keep your guide in a safe place for future reference

INSTALLER AND OWNER GUIDE

© Baxi Heating U.K. Limited 2006.

All rights reserved. No part of this publication may be reproduced in any material form (including photocopying), stored in any medium by electronic means (including in any retrieval system or database) or transmitted, in any form or by any means, whether electronic, mechanical, recording or otherwise, without the prior written permission of the copyright owner.

Applications for the copyright owner's permission to reproduce any part of this publication should be made, giving details of the proposed use, to the following address:
The Company Secretary, Baxi Heating UK Limited, Pentagon House, Sir Frank Whittle Road, Derby, DE21 4XA.

Warning: Any person who does any unauthorised act in relation to a copyright work may be liable to criminal prosecution and civil claims for damages.

CUSTOMER CARE

Thank you for choosing Baxi Fires Division

All Baxi Fires Division stoves are designed to meet the most stringent quality, performance and safety requirements to provide our customers with many years of trouble free service. This guide aims to improve your understanding and appreciation of your new Baxi Fires Division stove, by providing simple and informative instructions to enable you to install it and to ensure that you benefit from the excellent performance and features it has to offer.

If you require further assistance, the **Baxi Fires Division Technical Helpline** will be pleased to help.

Please telephone **08706 061 065** (local rates apply in the United Kingdom). In the Republic of Ireland please telephone **0044 8706 061 065**.

B A X I F I R E S D I V I S I O N

FOR OTHER USEFUL TELEPHONE NUMBERS SEE PAGE 9 OF THIS GUIDE.

Baxi Fires Division, Erdington, Birmingham B24 9QP.

www.firesandstoves.co.uk

Because our policy is one of constant development and improvement, details may vary slightly from those given in this publication

INSTALLER AND OWNER GUIDE

Safety First.

Baxi Fires Division stoves are CE Approved and designed to meet the appropriate British Standards and Safety Marks.



HANDLING AND UNPACKING

Before continuing any further with the installation of this stove please read the following:

Important instructions.

- The approximate lifting weight of the stove is 13kg.
- One person should be sufficient to lift the stove. If for any reason this weight is considered too heavy then obtain assistance.
- When lifting always keep your back straight. Bend your legs and not your back.
- Avoid twisting at the waist. It is better to reposition your feet.
- Avoid upper body / top heavy bending. Always bend from the knees rather than the waist. Do not lean forward or sideways whilst handling the stove.
- Always grip with the palm of the hand. Do not use the tips of fingers for support.
- Always keep the stove as close to the body as possible. This will minimise the cantilever action.
- Use gloves to provide additional grip.
- Always use assistance if required.

INSTALLER AND OWNER GUIDE

SAFETY

Always

- **Always** install the stove in accordance with this guide. If in doubt obtain expert advice.
- **Always** make sure the electrical socket is accessible and located adjacent to, but not above or behind the stove.
- **Always** disconnect the stove from the electrical supply before carrying out cleaning, maintenance or replacing the light bulbs.
- **Always** use a fireguard when young children and infirm persons can come into contact with the stove.
- **Always** use genuine Baxi Fires Division spares.

Never

- **Never** leave children unsupervised in a room where the stove is ON and unguarded.
- **Never** obstruct or cover the fan outlet or force items into stove openings.
- **Never** install or use the stove anywhere where water is in use, i.e. Bathrooms, Kitchens, Shower Rooms, Swimming Pools etc.
- **Never** use aerosols or steam cleaners on or around the stove.
- **Never** route the electric cable under carpet etc.
- **Never** install the stove close to curtains or combustible materials.
- **Never** use the stove to dry clothes etc.
- **Never** sit or stand on the stove.

POSITIONING THE STOVE

Please read this guide thoroughly before positioning the stove.

Do I need any tools?

The stove has been designed so that tools are not necessary during installation. A Philips or cross head screwdriver is required when replacing the bulbs.

Where can I position the stove?

The stove is designed to be free standing on a hard level surface. When positioning please bear the following points in mind:

- If you are placing the stove in an alcove, make sure that there is a gap of 150mm to side walls from the sides of the stove. This will ensure good air circulation (See figure 1).

INSTALLER AND OWNER GUIDE

- Keep hearth rugs and other soft furnishings etc. away from the front of the stove. They could obstruct the free flow of hot air from the fan and damage both soft furnishings and the stove.

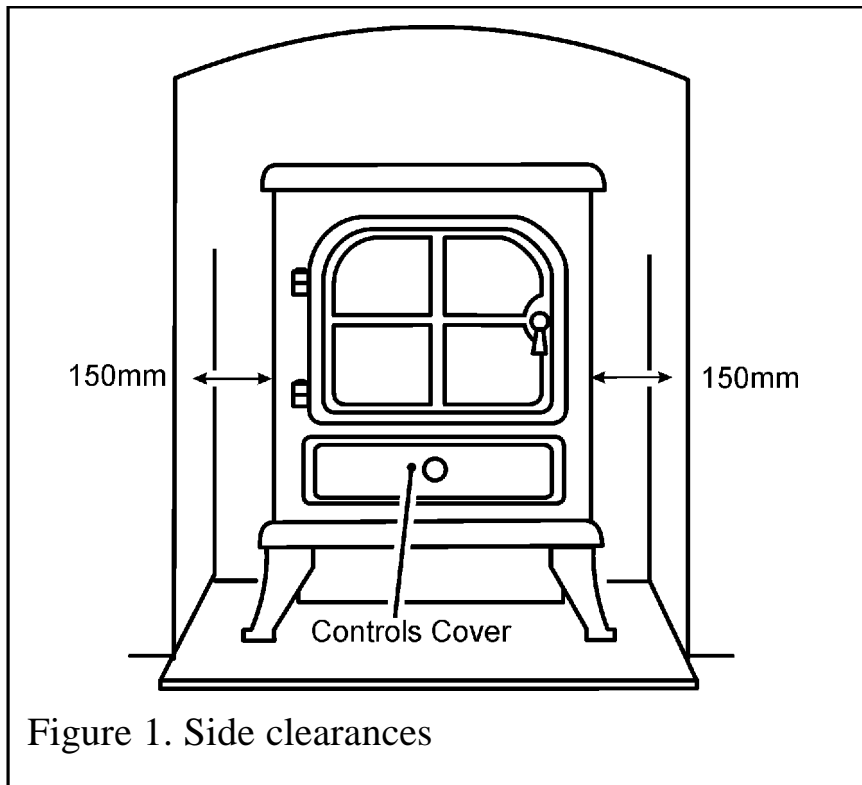

Figure 1. Side clearances

Important Electrical Safety

The stove must **not** be located in front of or under an electrical socket, the socket must always be accessible in order to disconnect the stove from the electrical supply for maintenance and cleaning.

Important! This stove must be earthed.

- The stove is supplied with a 3 pin 13 Amp fused re-wireable plug with 1mm² 3 core cable.
- The wires in the cable are coloured in accordance with the following code: -
 - Live = Brown
 - Neutral = Blue
 - Earth = Green / Yellow
- The electric supply must be safely routed from the stove to an electrical socket.

If the electric cable is damaged, to avoid a hazard it must be replaced by a Baxi Fires Division authorised service agent, or similarly qualified person (See page 9). All external wiring between the stove and the electrical supply shall comply with current IEE regulations.

INSTALLER AND OWNER GUIDE

Fitting the door.

The stove is supplied with the door removed in order to prevent damage during transportation. Unpack the door and hinge pins. Locate the door over the stove hinges and secure in place by firmly pushing a hinge pin into each door hinge.

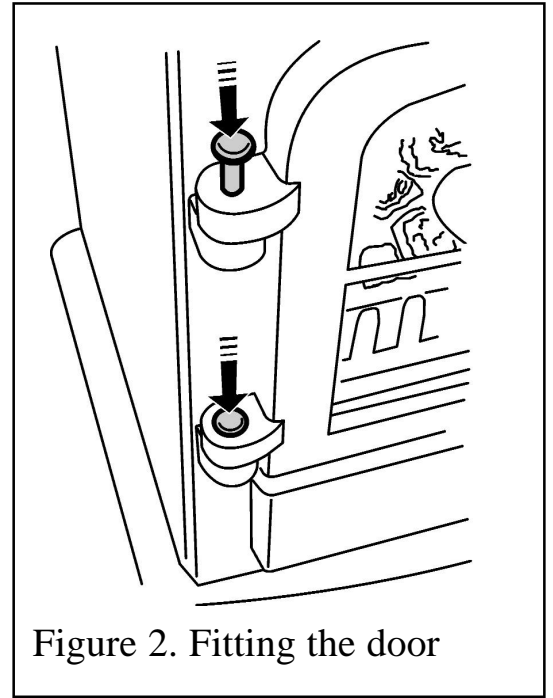

OPERATING THE STOVE

Never cover the stove or obstruct the opening at the base of the stove, this could cause overheating and consequent risk of fire.

The appliance can be controlled by the controls located underneath the controls cover (Pull knob on front of stove).

Stove Controls

The following switches are located under the controls cover.

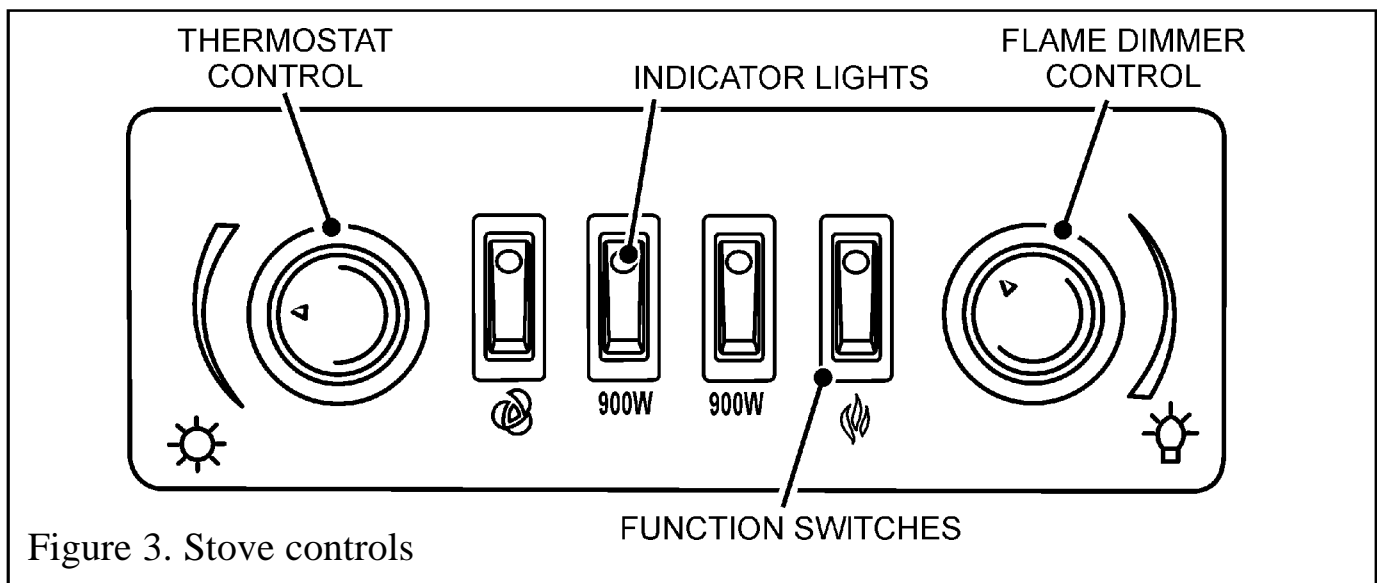

INSTALLER AND OWNER GUIDE

What do the switches control?



- Operates FAN. Can you used for cool air without the heater controls in operation.

- 900W** - Press one 900W switch for Low heat setting.
- Press two 900W switches for High heat setting. Heater will only work if the fan button has first been pressed.



- Switches flame and fuel effect on and off.

Flame Dimmer Control - Increases and decreases the brightness of the flicker effect.

Thermostat Control - Adjust to maintain room temperature (cycles between 900W and 1800W). The thermostat only operates on the 1800W setting (Both 900W indicator lights illuminated).

Important Safety.

Before undertaking maintenance or replacing the light bulb(s) always disconnect the stove from the electricity supply by removing the 3 pin plug and allowing the stove to cool.

How do I Clean my stove?

The stove and plastic parts need only to be wiped clean with a dry soft cloth, do not use polishes or abrasive materials.

I have a problem with my stove!

1. My stove is on but there is no light / low light.

- Try adjusting the flame dimmer control (See figure 3). Alternatively this is possibly a light bulb failure. Remove the light bulb as in the following section and check it in a table lamp that is known to work. If it does not work in the table lamp then it needs replacing as in the following sections.

The light bulbs fitted to this stove are 25Watt E14, 230Volt Edison fitting, candle style with a clear finish. Due to the indeterminate life span and ease of replacement, they are specifically excluded from the guarantee.

To replace the light bulb.

- Open the door by pulling on the handle.
- Remove the three screws on the front of the fuel basket. Behind the basket is a black metal strip which holds the fuel effect in place. Remove this by lifting up (See figure 4).
- Move the fuel bed forward and upward out of the way; you will have to hold the fuel effect up whilst replacing the light bulbs. It may be helpful to get another person to do this for you.

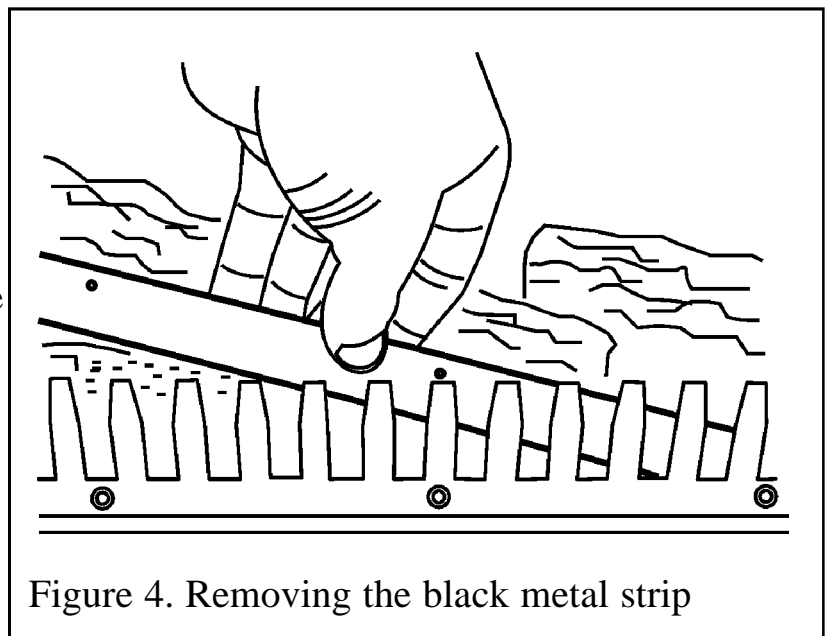

Figure 4. Removing the black metal strip

- Remove the faulty bulb by screwing the bulb anti - clockwise (See figure 5).

INSTALLER AND OWNER GUIDE

Fit the new bulb.

- Fit the new bulb by screwing it clockwise (See figure 5).
- Relocate the fuel effect.
- Relocate the black metal strip. The folded edge should be on the bottom.
- Secure using the three screws removed previously.

2. My stove is switched on but there is no light, fan or heat.

The first thing to do is check the wall socket. To do this plug in a known working appliance. If the appliance you have plugged in works then there is a

good chance that the problem lies with the 13 Amp fuse in the stove plug. If either fuse or socket is suspected, have them checked by an electrician.

3. My stove is on but there is no heat.

- Check that the thermostat on the stove is set above ambient room temperature.
- Alternatively a cut out device is fitted to the stove to prevent damage due to over heating. If it operates due to an obstruction in the airflow, the stove must be turned off and allowed to cool for 15 minutes and the obstruction removed before restarting.

4. I Have a problem that is different to those in the previous examples 1- 3.

Below is a list of Useful Telephone numbers

For general advice about your stove:

BAXI FIRES DIVISION TECHNICAL HELPLINE 08706 061 065.

To report faults or arrange for your stove to be serviced:

BAXI FIRES DIVISION SERVICE 08706 090 081.

For sales or product information:

BAXI FIRES DIVISION SALES 08706 061 067.

CALLERS IN THE REPUBLIC OF IRELAND

Call **0044 8706 061 065**

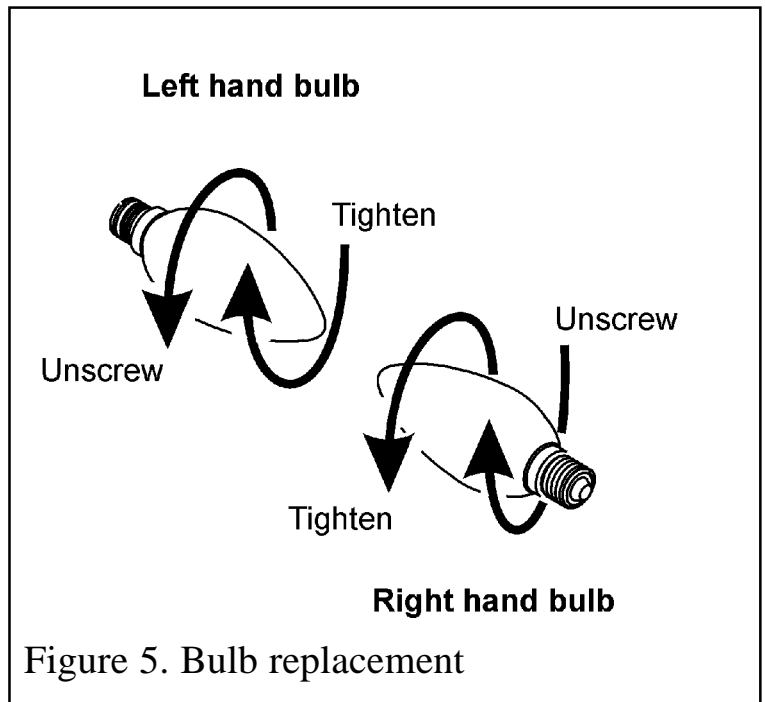

INSTALLER AND OWNER GUIDE

For spares inquiries

Spare parts are available nationwide via the ‘interpart stockist network’. For your local stockist consult Yellow pages under ‘Central Heating’.

When ordering spare parts please have the below information available. This will help us to deal with your call quicker and avoid you having to make a second call.

- Your Post Code
- Type of Stove (Electric or gas)
- The fault, problem or request.
- Model, Name and serial number (This information can be found on a small label on the rear of the stove).

What should I do when I’m ready to dispose of my stove?

The plug should be removed from the mains cable and the mains cable cut from the stove. These should be disposed of with the stove.

Environmental Protection.



Waste electrical products should not be disposed of with household waste. Please recycle where facilities exist. Check with your local authority or retailer for recycling advice.